

The University of Alabama in Huntsville  
ECE Department  
CPE 628 01  
Test 2  
November 18, 2008

Name: \_\_\_\_\_

1. (10 points) For the circuit shown, compute all the vectors that can detect h s-a-1 using the Boolean difference.

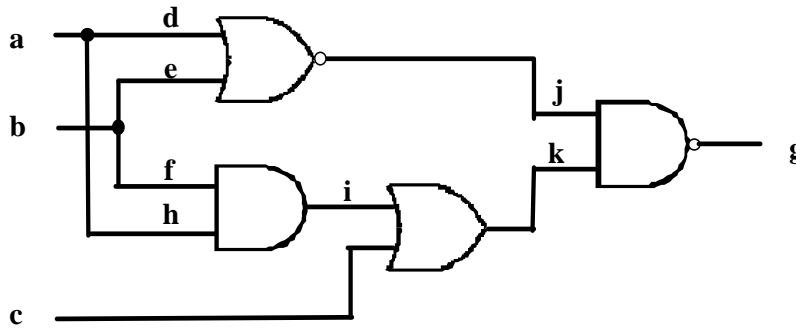

2. (5 points) List five different timing control schemes for BIST.

---

---

---

---

---

3. (10 points) Consider the following LFSR. Generate the sequence starting with 00001. Is this a maximal LFSR? What is its length?

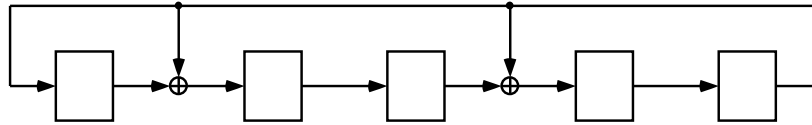

4. (15 points) For the circuit given,
- Compute the static logic implications of  $c = 0$ .
  - Compute the static logic implications of  $c = 1$ .
  - Compute the set of faults that are untestable when  $c = 0$ .
  - Compute the set of faults that are untestable when  $c = 1$ .
  - Compute the set of untestable faults based on the stem analysis of  $c$ .

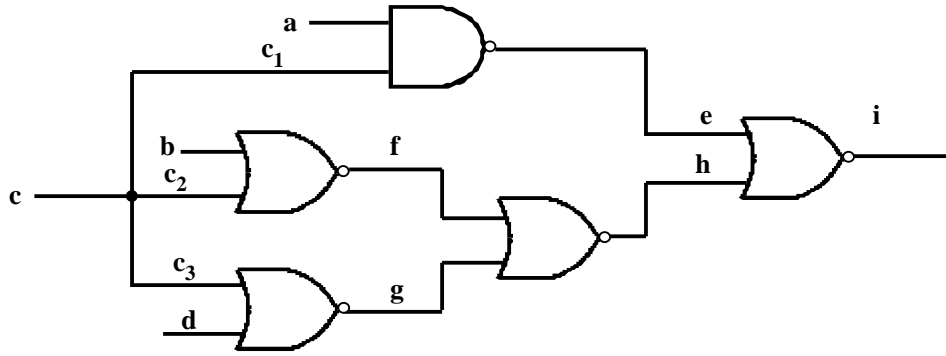

5. (1 point) \_\_\_\_\_ is a method for dramatically reducing the number of bits in the original circuit response during testing in which some information is lost.

6. (15 points) Using the circuit shown, use PODEM to compute a vector that can detect the fault q s-a-1.

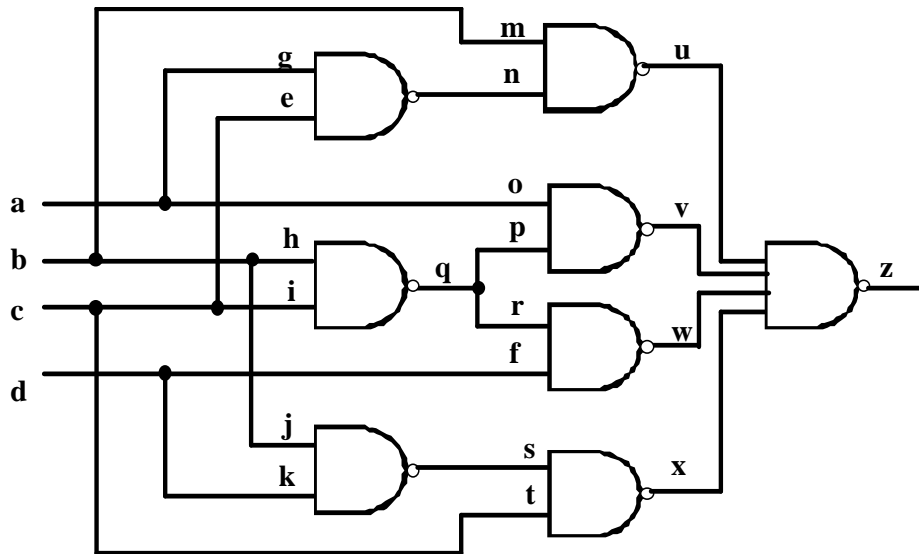

7. (1 point) The Logic BIST system most used in industry is named \_\_\_\_\_.
8. (1 point) An \_\_\_\_\_ fault originates at one clock domain and terminates at the same clock domain.

9. (15 points) Compute the signature of the SISR using  $f(x) = 1 + x + x^4$  given for the fault-free sequence  $M = \{110110010101011\}$ . Then, compute the signature for the faulty sequence  $M' = \{111100001100101\}$ . Explain why  $M'$  is detected or not detected.

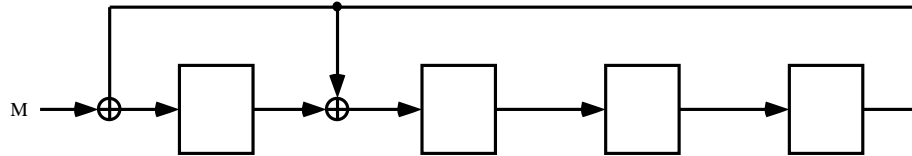

10. (1 point) For aligned skewed-load testing a clock \_\_\_\_\_ circuit is used to enable or disable selected shift or capture pulses.
11. (1 point) One type of delay fault test is known as a \_\_\_\_\_ delay test.

12. (10 points) For the circuit shown, use the D algorithm to compute a test vector for the fault  $i$  s-a-1.

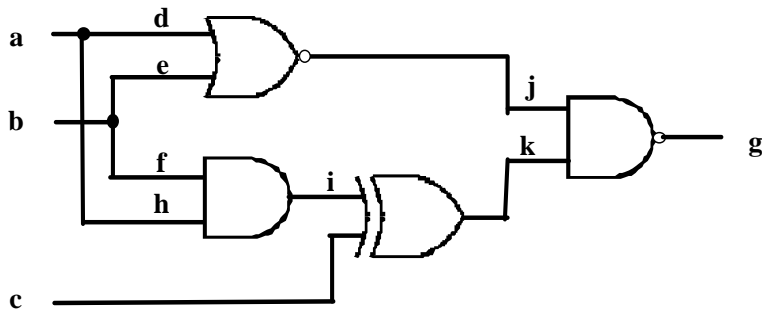

13. (15 points) For the circuit shown, insert two test points so the minimum detection probability for any fault in the circuit is greater than or equal to  $1/16$  and draw the resulting circuit. Assume control points are randomly activated.

