

CPE/EE 422/522

Chapter 2 – Introduction to VHDL

Dr. Rhonda Kay Gaede

UAH

UAH

Chapter 2

CPE/EE 422/522

Motivation for VHDL

- **Technology trends**
 - 1 billion transistor chip running at 20 GHz in 2007
- **Need for Hardware Description Languages**
 - Systems become more complex
 - Design at the gate and flip-flop level becomes very tedious and time consuming
- **HDLs allow**
 - Design and debugging at a higher level before conversion to the gate and flip-flop level
 - Tools for synthesis do the conversion
- **VHDL, Verilog**
- **VHDL – VHSIC Hardware Description Language**

Facts About VHDL

- Developed originally by DARPA
 - for specifying digital systems
- International IEEE standard (IEEE 1076-1993)
- Hardware Description, Simulation, Synthesis
- Provides a mechanism for digital design and reusable design documentation
- Support different description levels
 - Structural (specifying interconnections of the gates),
 - Dataflow (specifying logic equations), and
 - Behavioral (specifying behavior)
- Top-down, Technology Independent

Page 3 of 78

2.1 VHDL Description of Combinational Networks - The Basics

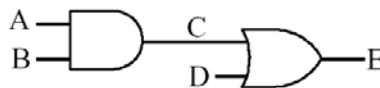

Concurrent Statements

```
C <= A and B after 5 ns;
E <= C or D after 5 ns;
```

If delay is not specified, "delta" delay is assumed

```
C <= A and B;
E <= C or D;
```

Order of concurrent statements is not important

```
E <= C or D;
C <= A and B;
```

This statement executes repeatedly

```
CLK <= not CLK after 10 ns;
```

This statement causes a simulation error

```
CLK <= not CLK;
```

Page 4 of 78

2.1 VHDL Description of Combinational Networks – Entity Architecture Pair

Full Adder Example

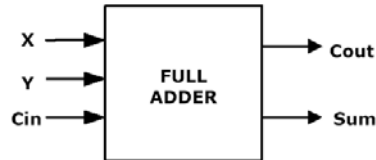

```

entity FullAdder is
  port (X, Y, Cin: in bit; -- Inputs
        Cout, Sum: out bit); -- Outputs
end FullAdder;

architecture Equations of FullAdder is
begin -- Concurrent Assignments
  Sum <= X xor Y xor Cin after 10 ns;
  Cout <= (X and Y) or (X and Cin) or (Y and Cin) after 10 ns;
end Equations;

```

2.1 VHDL Description of Combinational Networks – Hierarchy of VHDL Models

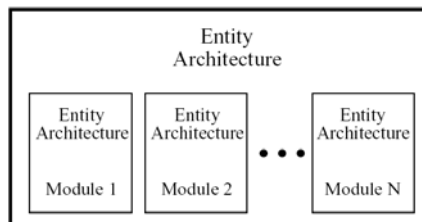

```

entity entity-name is
  [port(interface-signal-declaration);]
end [entity] [entity-name];

architecture architecture-name of entity-name is
  [declarations]
begin
  architecture body
end [architecture] [architecture-name];

```

2.1 VHDL Description of Combinational Networks - Adder4

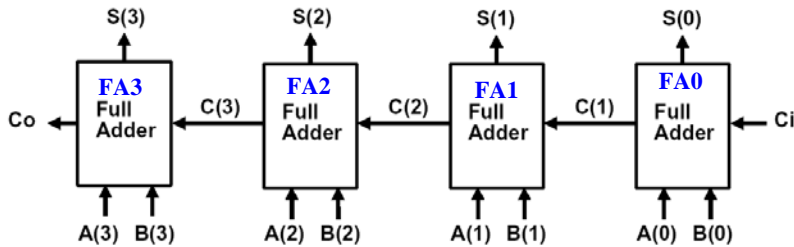

entity Adder4 is

```

port (A, B: in bit_vector(3 downto 0); Ci: in bit;      -- Inputs
        S: out bit_vector(3 downto 0); Co: out bit);    -- Outputs
end Adder4;
```

2.1 VHDL Description of Combinational Networks - Structural Adder4

entity Adder4 is

```

port (A, B: in bit_vector(3 downto 0); Ci: in bit;      -- Inputs
        S: out bit_vector(3 downto 0); Co: out bit);    -- Outputs
end Adder4;
```

architecture Structure **of** Adder4 **is**

component FullAdder

```

port (X, Y, Cin: in bit;      -- Inputs
        Cout, Sum: out bit);  -- Outputs
```

end component;

signal C: bit_vector(3 **downto** 1);

begin --instantiate four copies of the FullAdder

```

    FA0: FullAdder port map (A(0), B(0), Ci, C(1), S(0));
    FA1: FullAdder port map (A(1), B(1), C(1), C(2), S(1));
    FA2: FullAdder port map (A(2), B(2), C(2), C(3), S(2));
    FA3: FullAdder port map (A(3), B(3), C(3), Co, S(3));
```

end Structure;

2.1 VHDL Description of Combinational Networks - Providing Stimuli

```

list A B Co C Ci S -- put these signals on the output list
force A 1111      -- set the A inputs to 1111
force B 0001      -- set the B inputs to 0001
force Ci 1        -- set the Ci to 1
run 50            -- run the simulation for 50 ns
force Ci 0
force A 0101
force B 1110
run 50

```

ns	delta	a	b	co	c	ci	s
0	+0	0000	0000	0	000	0	0000
0	+1	1111	0001	0	000	1	0000
10	+0	1111	0001	0	001	1	1111
20	+0	1111	0001	0	011	1	1101
30	+0	1111	0001	0	111	1	1001
40	+0	1111	0001	1	111	1	0001
50	+0	0101	1110	1	111	0	0001
60	+0	0101	1110	1	110	0	0101
70	+0	0101	1110	1	100	0	0111
80	+0	0101	1110	1	100	0	0011

Page 9 of 78

2.1 VHDL Description of Combinational Networks - Testbench

```

entity FADDTST is
end FADDTST;

architecture TESTBENCH of FADDTST is
component Adder4 is
port (A, B: in bit_vector(3 downto 0); Ci: in bit; --Inputs
      S: out bit_vector(3 downto 0); Co: out bit); --Outputs
end component;
signal A,B,S : bit_vector(3 downto 0);
signal Ci, Co : bit;
begin
-- signals
A <= "1111" after 0 ns, "0101" after 50 ns;

B <= "0001" after 0 ns, "1110" after 50 ns;
Ci <= '1' after 0 ns, '0' after 50 ns;

-- component being tested
ct1: Adder4 port map (A,B,Ci,S,Co);
end TESTBENCH;

```

Page 10 of 78

2.1 VHDL Description of Combinational Networks - Altera Full Adder Simulation

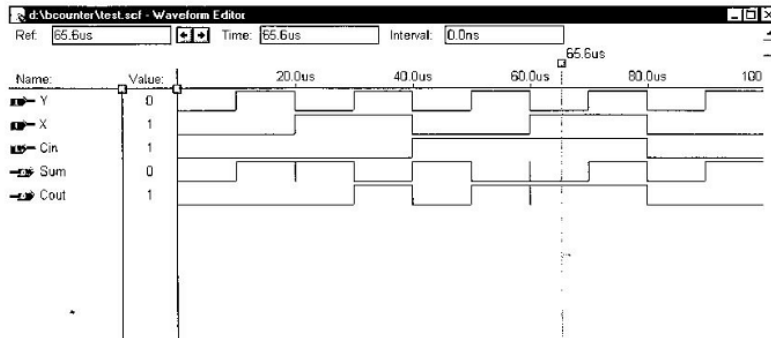

2.1 VHDL Description of Combinational Networks - Altera Adder4 Simulation

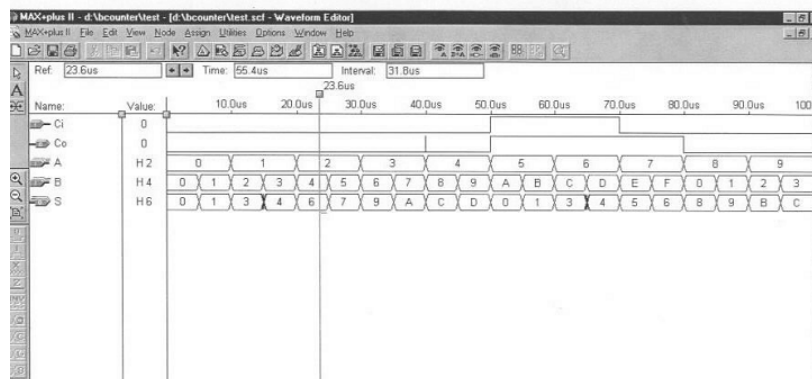

2.1 VHDL Description of Combinational Networks - Behavioral Adder4

```

-- Behavioral Description of 4 Bit Adder

-- Libraries
library IEEE;
USE IEEE.std_logic_1164.all; --to allow STD_LOGIC_VECTORS
USE IEEE.std_logic_arith.all;--to allow arithmetic operations
                                -- with the vectors
USE IEEE.std_logic_unsigned.all; --to allow integer conversions

entity ADDER4X is
  port(A,B: in STD_LOGIC_VECTOR (3 downto 0);    -- Inputs
        CI : in STD_LOGIC;                       -- Input
        S  : out STD_LOGIC_VECTOR (3 downto 0);  -- Outputs
        CO: out STD_LOGIC);                      -- Output
end ADDER4X;

```

2.1 VHDL Description of Combinational Networks - Behavioral Adder4

```

architecture BEHAVIORAL of ADDER4X is
-- temporary signal vectors which are 5 bits to keep up with CO
signal AA,BB,SS : STD_LOGIC_VECTOR (4 downto 0) := "00000";

begin
-- converting from 4 bit inputs to 5 bit ones to allow full
-- 5 bit arithmetic
  AA <= '0'&A; -- appending a leading 0 at most significant
  BB <= '0'&B; -- bit position of A and B

-- main equation for 4 bit adder (describes desired behavior)
  SS <= AA + BB + CI;

-- relating this internal output to the port output signals
  S <= SS(3 downto 0); -- 4 bit Sum
  CO <= SS(4);        -- carry out
end BEHAVIORAL;

```

2.1 VHDL Description of Combinational Networks - Behavioral Adder4 Simulation

ps	delta	a	b	ci	s
0	+0	0000	0000	0	0000
0	+1	1111	0001	0	0000
0	+3	1111	0001	0	0001
0	+4	1111	0001	1	0001
50000	+0	0101	1110	1	0001
50000	+2	0101	1110	1	0000
50000	+3	0101	1110	1	0011

	A	1111
	+B	0001
	+CI	1
		<u>10001</u>
	CO	1
	S	0001

	A	0101
	+B	1110
	+CI	0
		<u>10011</u>
	CO	1
	S	0011

2.2 Modeling Flip-Flops Using VHDL Processes - The Process Statement

General form of process

```

process(sensitivity-list)
begin
    sequential-statements
end process;
    
```

- Whenever one of the signals in the sensitivity list changes, the sequential statements are executed in sequence one time

2.2 Modeling Flip-Flops Using VHDL Processes - Sequential Statements

A, B, C, D are integers A=1, B=2, C=3, D=0 D changes to 4 at time 10

```
A <= B; -- statement 1
B <= C; -- statement 2
C <= D; -- statement 3
```

```
process (B, C, D)
begin
  A <= B; -- statement 1
  B <= C; -- statement 2
  C <= D; -- statement 3
end process;
```

time delta A B C D

time delta A B C D

2.2 Modeling Flip-Flops Using VHDL Processes - Modeling a D Flip-Flop

```
entity DFF is
  port (D, CLK: in bit;
        Q: out bit; QN: out bit := '1');
  -- initialize QN to '1' since bit signals are initialized to '0' by default
end DFF;
```

```
architecture SIMPLE of DFF is
begin
  process (CLK) -- process is executed when CLK changes
  begin
    if CLK = '1' then -- rising edge of clock
      Q <= D after 10 ns;
      QN <= not D after 10 ns;
    end if;
  end process;
end SIMPLE;
```

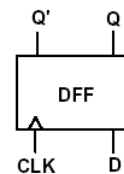

2.2 Modeling Flip-Flops Using VHDL Processes - Modeling a D Latch

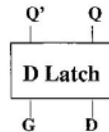

```

entity DLATCH is
  port (D, G: in bit;
        Q: out bit; QN: out bit := '1');
end DLATCH;

architecture SIMPLE of DLATCH is
begin
  process (G,D) --process is executed when either G or D changes
  begin
    if G = '1' then -- pass D through when G=1
      Q <= D after 10 ns;
      QN <= not D after 10 ns;
    end if;
  end process;
end SIMPLE;

```

2.2 Modeling Flip-Flops Using VHDL Processes - D Flip-Flop versus D Latch

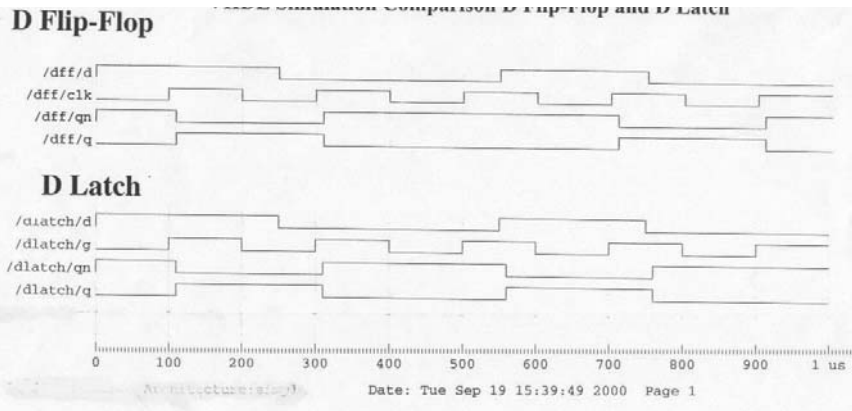

2.2 Modeling Flip-Flops Using VHDL Processes - Altera DFF Simulation

Altera's Simulation of D Flip-Flop

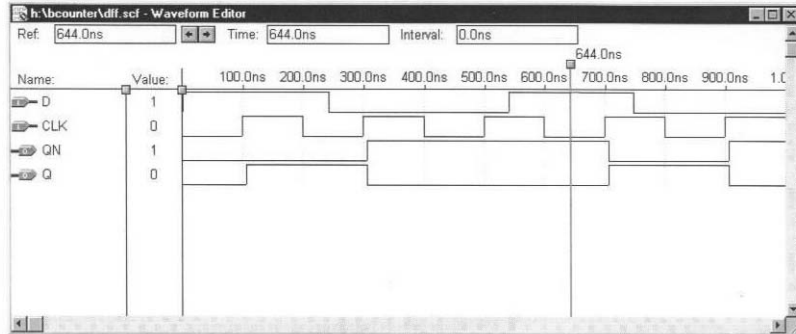

2.2 Modeling Flip-Flops Using VHDL Processes - Altera D Latch Simulation

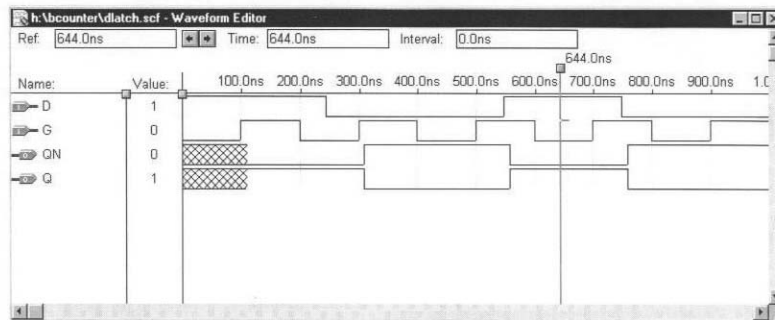

Building a Shift Register with D Flip-flop Building Blocks

```
-- Simple VHDL Model of a D Flip Flop -- similar to one
-- in text
```

```
-- Libraries
library IEEE;
USE IEEE.std_logic_1164.all; -- to allow STD_LOGIC
```

```
entity DFFP is
  port (D, CLK: in STD_LOGIC;
        Q: out STD_LOGIC; QN: out STD_LOGIC := '1');
end DFFP;
```

```
architecture SIMPLE of DFFP is
begin
  process(CLK)
  begin
    if CLK = '1' then
      Q <= D;
      QN <= not D;
    end if;
  end process;
end SIMPLE;
```

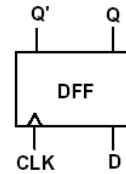

Page 23 of 78

Building a Shift Register with D Flip-flop Building Blocks

```
-- A Structural Description of 4 Bit Shift Register
```

```
-- Libraries
library IEEE;
USE IEEE.std_logic_1164.all; --to allow STD_LOGIC_VECTORS
USE IEEE.std_logic_arith.all;--to allow arithmetic operation
USE IEEE.std_logic_unsigned.all; --to allow integer conversions
```

```
entity SHIFT4S is
  port(CLK,DI : in STD_LOGIC; -- Inputs
        O : inout STD_LOGIC_VECTOR (3 downto 0)); -- Outputs
end SHIFT4S;
```

```
architecture STRUCT of SHIFT4S is
  signal QNX : STD_LOGIC_VECTOR (3 downto 0) := "0000";
  component DFFP is
    port (D, CLK: in STD_LOGIC;
          Q: out STD_LOGIC; QN: out STD_LOGIC := '1');
  end component;
begin
  CT1: DFFP port map (DI,CLK,O(0),QNX(0));
  CT2: DFFP port map (O(0),CLK,O(1),QNX(1));
  CT3: DFFP port map (O(1),CLK,O(2),QNX(2));
  CT4: DFFP port map (O(2),CLK,O(3),QNX(3));
end STRUCT;
```

Page 24 of 78

Testing the Shift Register

```

-- Libraries
library IEEE;
USE IEEE.std_logic_1164.all; --to allow STD_LOGIC_VECTORS
USE IEEE.std_logic_arith.all;--to allow arithmetic operations
USE IEEE.std_logic_unsigned.all; --to allow integer conversions

entity SHIFT4T is
end SHIFT4T;

architecture TESTBENCH of SHIFT4T is
component SHIFT4S is
port(CLK,DI : in STD_LOGIC; -- Inputs
      O : inout STD_LOGIC_VECTOR (3 downto 0)); -- Outputs
end component;

signal O : STD_LOGIC_VECTOR(3 downto 0) := "0000";
signal CLK, DI : STD_LOGIC := '0';
begin
-- signals
CLK <= not CLK after 50 ns;

DI <= '1' after 0 ns, '0' after 100 ns, '1' after 200 ns,
      '0' after 300 ns, '1' after 400 ns;

-- component being tested
CT1: SHIFT4S port map (CLK,DI,O);
end TESTBENCH;

```

Page 25 of 78

A Behavioral Shift Register Model

```

-- A Behavioral Description of 4 Bit Shift Register

-- Libraries
library IEEE;
USE IEEE.std_logic_1164.all; --to allow STD_LOGIC_VECTORS
USE IEEE.std_logic_arith.all;--to allow arithmetic operations
USE IEEE.std_logic_unsigned.all; --to allow integer conversions

entity SHIFT4B is
port(CLK,DI : in STD_LOGIC; -- Inputs
      O : inout STD_LOGIC_VECTOR (3 downto 0)); -- Outputs
end SHIFT4B;

architecture BEHAVIORAL of SHIFT4B is
begin
process (CLK)
begin
if (CLK = '1') then
O(0) <= DI;
O(1) <= O(0);
O(2) <= O(1);
O(3) <= O(2);
end if;
end process;
end BEHAVIORAL;

```

Page 26 of 78

Another Behavioral Shift Register Model

```
-- Another Behavioral Description of a 4 Bit Shift Register

-- Libraries
library IEEE;
USE IEEE.std_logic_1164.all; --to allow STD_LOGIC_VECTORS
USE IEEE.std_logic_arith.all;--to allow arithmetic operations
USE IEEE.std_logic_unsigned.all; --to allow integer conversions

entity SHIFT4B is
  port(CLK,DI : in STD_LOGIC; -- Inputs
        O : inout STD_LOGIC_VECTOR (3 downto 0)); -- Outputs
end SHIFT4B;

architecture BEHAVIORAL of SHIFT4B is
begin
process (CLK)
  begin
    if (CLK = '1') then
      O <= O(2 downto 0) & DI;
    end if;
  end process;
end BEHAVIORAL;
```

Page 27 of 78

Shift Register Simulation Results

```
          clk
      ps delta di  o
=====
0         +0 0 0 UUUU
0         +1 0 1 UUUU
50000    +0 1 1 UUUU
50000    +1 1 1 UUU1
100000   +0 0 0 UUU1
150000   +0 1 0 UUU1
150000   +1 1 0 UU10
200000   +0 0 1 UU10
250000   +0 1 1 UU10
250000   +1 1 1 U101
300000   +0 0 0 U101
350000   +0 1 0 U101
350000   +1 1 0 1010
400000   +0 0 1 1010
450000   +0 1 1 1010
450000   +1 1 1 0101
500000   +0 0 1 0101
550000   +0 1 1 0101
550000   +1 1 1 1011
600000   +0 0 1 1011
650000   +0 1 1 1011
650000   +1 1 1 0111
700000   +0 0 1 0111
750000   +0 1 1 0111
750000   +1 1 1 1111
800000   +0 0 1 1111
```

Page 28 of 78

2.2 Modeling Flip-Flops Using VHDL Processes - Modeling a JK Flip-Flop

```

entity JKFF is
  port (SN, RN, J, K, CLK: in bit;           -- inputs
        Q: inout bit; QN: out bit := '1');  -- see Note 1
end JKFF;

architecture JKFF1 of JKFF is
begin
  process (SN, RN, CLK)                    -- see Note 2
  begin
    if RN = '0' then Q <= '0' after 10 ns; -- RN=0 will clear the FF
    elsif SN = '0' then Q <= '1' after 10 ns; -- SN=0 will set the FF
    elsif CLK = '0' and CLK'event then     -- see Note 3
      Q <= (J and not Q) or (not K and Q) after 10 ns; -- see Note 4
    end if;
  end process;
  QN <= not Q;                             -- see Note 5
end JKFF1;

```

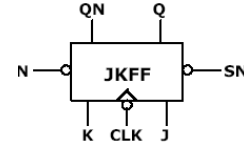

2.2 Modeling Flip-Flops Using VHDL Processes - Nested If-then-else

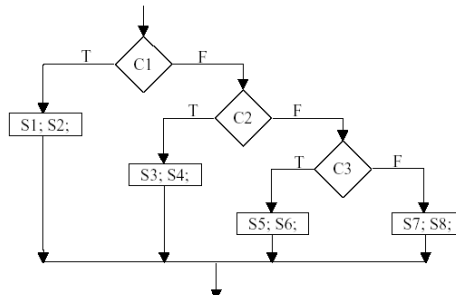

```

if (C1) then S1; S2;
  else if (C2) then S3; S4;
    else if (C3) then S5; S6;
      else S7; S8;
    end if;
  end if;
end if;

if (C1) then S1; S2;
  elsif (C2) then S3; S4;
  elsif (C3) then S5; S6;
  else S7; S8;
end if;

```

2.3 VHDL Models for a Multiplexer

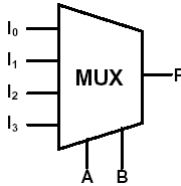

```
F <= (not A and not B and I0) or
      (not A and B and I1) or
      (A and not B and I2) or
      (A and B and I3);
```

MUX model using a *conditional signal assignment statement*:

```
F <= I0 when Sel = 0
      else I1 when Sel = 1
      else I2 when Sel = 2
      else I3;
```

The case statement has the general form:

```
case Sel is
  when 0 => F <= I0;
  when 1 => F <= I1;
  when 2 => F <= I2;
  when 3 => F <= I3;
end case;
```

```
case expression is
  when choice1 => sequential statements1
  when choice2 => sequential statements2
  ...
  [when others => sequential statements]
end case;
```

2.3 VHDL Models for a Multiplexer - If Statements

```
library IEEE;
use IEEE.std_logic_1164.all;
use IEEE.std_logic_unsigned.all;
entity SELECTOR is
  port (
    A :in std_logic_vector(15 downto 0);
    SEL:in std_logic_vector( 3 downto 0);
    Y :out std_logic);
end SELECTOR;

architecture RTL1 of SELECTOR is
begin
  p0 : process (A, SEL)
  begin
    if (SEL = "0000") then      Y <= A(0);
    elsif (SEL = "0001") then  Y <= A(1);
    elsif (SEL = "0010") then  Y <= A(2);
    elsif (SEL = "0011") then  Y <= A(3);
    elsif (SEL = "0100") then  Y <= A(4);
    elsif (SEL = "0101") then  Y <= A(5);
    elsif (SEL = "0110") then  Y <= A(6);
    elsif (SEL = "0111") then  Y <= A(7);
    elsif (SEL = "1000") then  Y <= A(8);
    elsif (SEL = "1001") then  Y <= A(9);
    elsif (SEL = "1010") then  Y <= A(10);
    elsif (SEL = "1011") then  Y <= A(11);
    elsif (SEL = "1100") then  Y <= A(12);
    elsif (SEL = "1101") then  Y <= A(13);
    elsif (SEL = "1110") then  Y <= A(14);
    else      Y <= A(15);
    end if;
  end process;
end RTL1;
```

2.3 VHDL Models for a Multiplexer - Conditional Concurrent Statement

```

library IEEE;
use IEEE.std_logic_1164.all;
use IEEE.std_logic_unsigned.all;
entity SELECTOR is
  port (
    A : in  std_logic_vector(15 downto 0);
    SEL : in  std_logic_vector( 3 downto 0);
    Y : out std_logic);
end SELECTOR;

architecture RTL3 of SELECTOR is
begin
  with SEL select
    Y <= A(0)  when "0000",
         A(1)  when "0001",
         A(2)  when "0010",
         A(3)  when "0011",
         A(4)  when "0100",
         A(5)  when "0101",
         A(6)  when "0110",
         A(7)  when "0111",
         A(8)  when "1000",
         A(9)  when "1001",
         A(10) when "1010",
         A(11) when "1011",
         A(12) when "1100",
         A(13) when "1101",
         A(14) when "1110",
         A(15) when others;
end RTL3;

```

2.3 VHDL Models for a Multiplexer - Case Statement

```

library IEEE;
use IEEE.std_logic_1164.all;
use IEEE.std_logic_unsigned.all;
entity SELECTOR is
  port (
    A : in  std_logic_vector(15 downto 0);
    SEL : in  std_logic_vector( 3 downto 0);
    Y : out std_logic);
end SELECTOR;

architecture RTL2 of SELECTOR is
begin
  p1 : process (A, SEL)
  begin
    case SEL is
      when "0000" => Y <= A(0);
      when "0001" => Y <= A(1);
      when "0010" => Y <= A(2);
      when "0011" => Y <= A(3);
      when "0100" => Y <= A(4);
      when "0101" => Y <= A(5);
      when "0110" => Y <= A(6);
      when "0111" => Y <= A(7);
      when "1000" => Y <= A(8);
      when "1001" => Y <= A(9);
      when "1010" => Y <= A(10);
      when "1011" => Y <= A(11);
      when "1100" => Y <= A(12);
      when "1101" => Y <= A(13);
      when "1110" => Y <= A(14);
      when others => Y <= A(15);
    end case;
  end process;
end RTL2;

```

2.3 VHDL Models for a Multiplexer - Register Transfer Level

```

library IEEE;
use IEEE.std_logic_1164.all;
use IEEE.std_logic_unsigned.all;
entity SELECTOR is
  port (
    A  : in  std_logic_vector(15 downto 0);
    SEL : in  std_logic_vector( 3 downto 0);
    Y   : out std_logic);
end SELECTOR;

architecture RTL4 of SELECTOR is
begin
  Y <= A(conv_integer(SEL));
end RTL4;

```

2.4 Compilation and Simulation of VHDL

- Compiler (Analyzer) – checks the VHDL source code
 - does it conforms with VHDL syntax and semantic rules
 - are references to libraries correct
- Intermediate form used by a simulator or by a synthesizer
- Elaboration
 - create ports, allocate memory storage, create interconnections, ...
 - establish mechanism for executing of VHDL processes

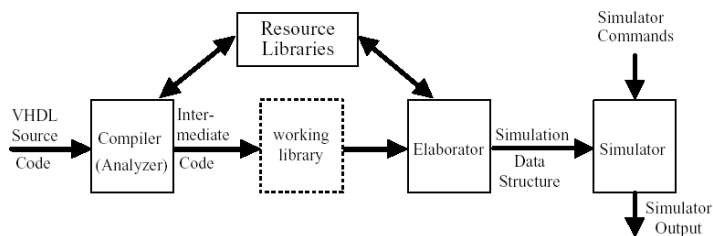

2.4 Compilation and Simulation of VHDL - Transport Delay

- Transport delay must be explicitly specified
 - I.e. keyword “TRANSPORT” must be used
- Signal will assume its new value after specified delay

```
-- TRANSPORT delay example
Output <= TRANSPORT NOT Input AFTER 10 ns;
```

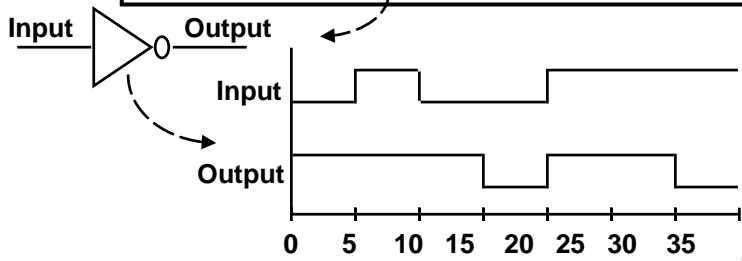

2.4 Compilation and Simulation of VHDL - Inertial Delay

- Provides for specification propagation delay and input pulse width, i.e. 'inertia' of output:

```
target <= [REJECT time_expression] INERTIAL waveform;
```

- Inertial delay is default and REJECT is optional:

```
Output <= NOT Input AFTER 10 ns;
-- Propagation delay and minimum pulse width are 10ns
```

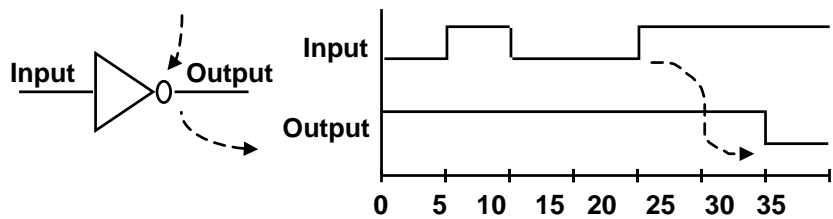

2.4 Compilation and Simulation of VHDL - Modeling Propagation Delay

- Example of gate with 'inertia' smaller than propagation delay
 - e.g. Inverter with propagation delay of 10ns which suppresses pulses shorter than 5ns

```
Output <= REJECT 5ns INERTIAL NOT Input AFTER 10ns;
```

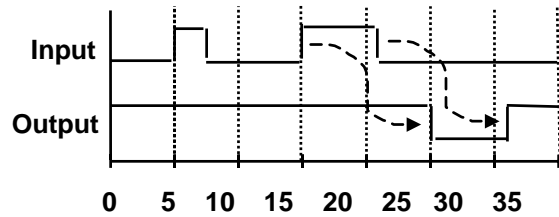

- Note: the REJECT feature is new to VHDL 1076-1993

2.4 Compilation and Simulation of VHDL - Simulation Example

Signal Drivers

```
entity simulation_example is
end simulation_example;

architecture test1 of simulation_example is
    signal A,B: bit;
begin
    P1: process(B)
    begin
        A <= '1';
        A <= transport '0' after 5 ns;
    end process P1;

    P2: process(A)
    begin
        if A = '1' then B <= not B after 10 ns; end if;
    end process P2;
end test1;
```

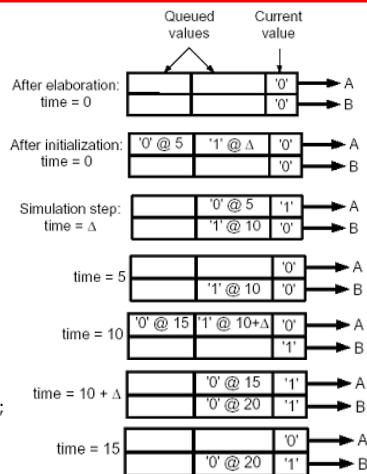

2.5 Modeling Sequential Circuits

Mealy Machine for 8421 BCD to 8421 BCD + 3 bit serial converter

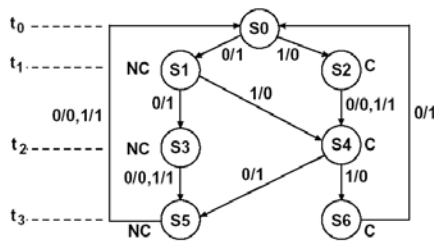

PS	NS		Z	
	X = 0	X = 1	X = 0	X = 1
S0	S1	S2	1	0
S1	S3	S4	1	0
S2	S4	S4	0	1
S3	S5	S5	0	1
S4	S5	S6	1	0
S5	S0	S0	0	1
S6	S0	-	1	-

How to model this in VHDL?

2.5 Modeling Sequential Circuits - Behavioral VHDL

```

entity SM1_2 is
  port(X, CLK: in bit; Z: out bit);
end SM1_2;

architecture Table of SM1_2 is
  signal State, Nextstate: integer := 0;
begin
  process(State,X) --Combinational Network
  begin
    case State is
      when 0 =>
        if X='0' then Z<='1'; Nextstate<=1; end if;
        if X='1' then Z<='0'; Nextstate<=2; end if;
      when 1 =>
        if X='0' then Z<='1'; Nextstate<=3; end if;
        if X='1' then Z<='0'; Nextstate<=4; end if;
      when 2 =>
        if X='0' then Z<='0'; Nextstate<=4; end if;
        if X='1' then Z<='1'; Nextstate<=4; end if;
      when 3 =>
        if X='0' then Z<='0'; Nextstate<=5; end if;
        if X='1' then Z<='1'; Nextstate<=5; end if;
      when 4 =>
        if X='0' then Z<='1'; Nextstate<=5; end if;
        if X='1' then Z<='0'; Nextstate<=6; end if;
      when 5 =>
        if X='0' then Z<='0'; Nextstate<=0; end if;
        if X='1' then Z<='1'; Nextstate<=0; end if;
      when 6 =>
        if X='0' then Z<='1'; Nextstate<=0; end if;
        when others => null; -- should not occur
    end case;
  end process;

  process(CLK) -- State Register
  begin
    if CLK='1' then
      State <= Nextstate; -- rising edge of clock
    end if;
  end process;
end Table;
    
```

PS	NS		Z	
	X=0	X=1	X=0	X=1
S0	S1	S2	1	0
S1	S3	S4	1	0
S2	S4	S4	0	1
S3	S5	S5	0	1
S4	S5	S6	1	0
S5	S0	S0	0	1
S6	S0	-	1	-

Two processes:

- the first represents the combinational network;
- the second represents the state register

2.5 Modeling Sequential Circuits - Dataflow VHDL Model

-- The following is a description of the sequential machine of
-- Figure 1-17 in terms of its next state equations.
-- The following state assignment was used:
-- S0-->0; S1-->4; S2-->5; S3-->7; S4-->6; S5-->3; S6-->2

```
entity SM1_2 is
  port(X,CLK: in bit;
        Z: out bit);
end SM1_2;

architecture Equations1_4 of SM1_2 is
  signal Q1,Q2,Q3: bit;
begin
  process(CLK)
  begin
    if CLK='1' then -- rising edge of clock
      Q1<=not Q2 after 10 ns;
      Q2<=Q1 after 10 ns;
      Q3<=(Q1 and Q2 and Q3) or (not X and Q1 and not Q3) or
        (X and not Q1 and not Q2) after 10 ns;
    end if;
  end process;
  Z<=(not X and not Q3) or (X and Q3) after 20 ns;
end Equations1_4;
```

$$Q_1(t^+) = Q_2$$

$$Q_2(t^+) = Q_1$$

$$Q_3(t^+) = Q_1 Q_2 Q_3 + X' Q_1 Q' _3 + X' Q' _1 Q' _2$$

$$Z = X' Q' _3 + X Q_3$$

Page 43 of 78

2.5 Modeling Sequential Circuits - Structural Model

```
library BITLIB;
use BITLIB.bit_pack.all;

entity SM1_2 is
  port(X,CLK: in bit;
        Z: out bit);
end SM1_2;

architecture Structure of SM1_2 is
  signal A1,A2,A3,A5,A6,D3: bit:= '0';
  signal Q1,Q2,Q3: bit:= '0';
  signal Q1N,Q2N,Q3N, XN: bit:= '1';
begin
  I1: Inverter port map (X,XN);
  G1: Nand3 port map (Q1,Q2,Q3,A1);
  G2: Nand3 port map (Q1,Q3N,XN,A2);
  G3: Nand3 port map (X,Q1N,Q2N,A3);
  G4: Nand3 port map (A1,A2,A3,D3);
  FF1: DFF port map (Q2N,CLK,Q1,Q1N);
  FF2: DFF port map (Q1,CLK,Q2,Q2N);
  FF3: DFF port map (D3,CLK,Q3,Q3N);
  G5: Nand2 port map (X,Q3,A5);
  G6: Nand2 port map (XN,Q3N,A6);
  G7: Nand2 port map (A5,A6,Z);
end Structure
```

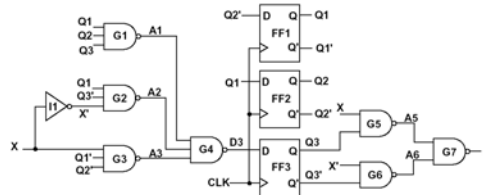

Package bit_pack is a part of library
BITLIB –
includes gates, flip-flops, counters
(See Appendix B for details)

Page 44 of 78

2.12 VHDL Model for A 74163 Counter - Truth Table

Control Signals			Next State				
ClrN	LdN	P•T	Q3*	Q2*	Q1*	Q0*	
0	X	X	0	0	0	0	(clear)
1	0	X	D3	D2	D1	D0	(parallel load)
1	1	0	Q3	Q2	Q1	Q0	(no change)
1	1	1	present state + 1				(increment count)

Generate a Cout in state 15 if T=1

$$\text{Cout} = Q_3 Q_2 Q_1 Q_0 T$$

2.12 VHDL Model for a 74163 Counter - VHDL

```
-- 74163 FULLY SYNCHRONOUS COUNTER
library BITLIB; -- contains int2vec and vec2int functions
use BITLIB.bit_pack.all;

entity c74163 is
  port(LdN, ClrN, P, T, CK: in bit; D: in bit_vector(3 downto 0);
        Cout: out bit; Q: inout bit_vector(3 downto 0));
end c74163;

architecture b74163 of c74163 is
begin
  Cout <= Q(3) and Q(2) and Q(1) and Q(0) and T;
  process
  begin
    wait until CK = '1'; -- change state on rising edge
    if ClrN = '0' then Q <= "0000";
    elsif LdN = '0' then Q <= D;
    elsif (P and T) = '1' then
      Q <= int2vec(vec2int(Q)+1,4);
    end if;
  end process;
end b74163;
```

2.12 VHDL Model for a 74163 Counter - Cascade Counters (Block Diagram)

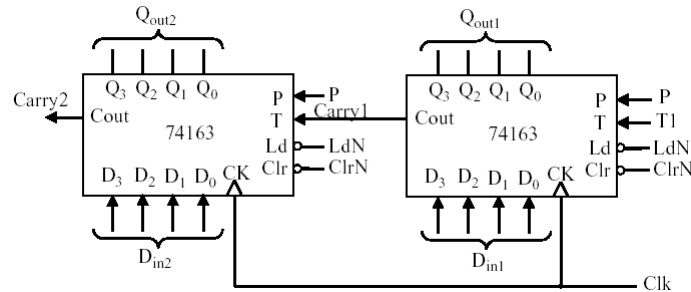

2.12 VHDL Model for a 74163 Counter - Cascaded Counters (VHDL)

```

library BITLIB;
use BITLIB.bit_pack.all;

entity c74163test is
  port(ClrN,LdN,P,T1,Clk: in bit;
        Din1, Din2: in bit_vector(3 downto 0);
        Qout1, Qout2: inout bit_vector(3 downto 0);
        Carry2: out bit);
end c74163test;

architecture tester of c74163test is
  component c74163
    port(LdN, ClrN, P, T, CK: in bit; D: in bit_vector(3 downto 0);
          Cout: out bit; Q: inout bit_vector(3 downto 0) );
  end component;
  signal Carry1: bit;
  signal Count: integer;
  signal temp: bit_vector(7 downto 0);
begin
  ct1: c74163 port map (LdN,ClrN,P,T1,Clk,Din1,Carry1,Qout1);
  ct2: c74163 port map (LdN,ClrN,P,Carry1,Clk,Din2,Carry2,Qout2);
  temp <= Qout2 & Qout1;
  Count <= vec2int(temp);
end tester;

```

2.5 Modeling a Sequential Machine - Wait Statements

- ... an alternative to a sensitivity list
 - Note: a process cannot have both wait statement(s) and a sensitivity list
- Generic form of a process with wait statement(s)

```

process
begin
  sequential-statements
  wait statement
  sequential-statements
  wait-statement
  ...
end process;

```

How do wait statements work?

- Execute sequential statements until a wait statement is encountered.
- Wait until the specified condition is satisfied.
- Then execute the next set of sequential statements until the next wait statement is encountered.
- ...
- When the end of the process is reached start over again at the beginning.

2.5 Modeling a Sequential Machine - Forms of Wait Statements

```

wait on sensitivity-list;
wait for time-expression;
wait until boolean-expression;

```

- Wait on
 - _____ one of the _____ changes
- Wait for
 - waits until the _____ by the time expression has _____
 - What is this:
wait for 0 ns;
- Wait until
 - the boolean expression is evaluated whenever one of _____ changes, and the process continues execution when the expression evaluates to _____

2.5 Modeling a Sequential Machine - Using `wait` Statements

```

wait on CLK, X;
if rising_edge(CLK) then
    State <= Nextstate;
    wait for 0 ns;
end if;
end process;

```

-- rising_edge function is in BITLIB *
-- wait for State to be updated

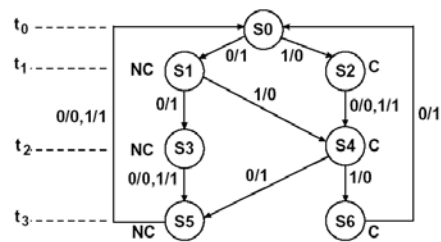

2.6 Variables, Signals, Constants - Variables

- What they are for:
Local storage in _____,
_____, and _____
- Declaring variables

```

variable list_of_variable_names : type_name
[ := initial value ];

```

- Variables must be declared within the process in which they are used and are local to the process
 - Note: exception to this is SHARED variables
- Variables in processes are _____, they retain their value from one activation to the next

2.6 Variables, Signals, Constants - Signals

- Signals must be declared _____ a process
- Declaration form

```
signal list_of_signal_names : type_name  
[ := initial value ];
```

- Declared in an architecture can be used anywhere within that architecture
- Declared in the _____

2.6 Variables, Signals, Constants - Constants

- Declaration form

```
constant constant_name : type_name := constant_value;
```

```
constant delay1 : time := 5 ns;
```

- Constants declared at the start of an architecture can be used anywhere within that architecture
- Constants declared within a process are local to that process

2.6 Variables, Signals, Constants - Variables versus Signals

- Variable assignment statement

```
variable_name := expression;
```

- expression is evaluated and the variable is _____ updated
(no delay, not even delta delay)

- Signal assignment statement

```
signal_name <= expression [after delay];
```

- expression is evaluated and the signal is _____; if no delay is specified the signal is scheduled to be updated after a delta delay

2.6 Variables, Signals, Constants - Variables versus Signals (continued)

Process Using Variables

```
entity dummy is
end dummy;

architecture var of dummy is
  signal trigger, sum: integer:=0;
begin
  process
    variable var1: integer:=1;
    variable var2: integer:=2;
    variable var3: integer:=3;
  begin
    wait on trigger;
    var1 := var2 + var3;
    var2 := var1;
    var3 := var2;
    sum <= var1 + var2 + var3;
  end process;
end var;

Sum = ?
```

Process Using Signals

```
entity dummy is
end dummy;

architecture sig of dummy is
  signal trigger, sum: integer:=0;
  signal sig1: integer:=1;
  signal sig2: integer:=2;
  signal sig3: integer:=3;
begin
  process
  begin
    wait on trigger;
    sig1 <= sig2 + sig3;
    sig2 <= sig1;
    sig3 <= sig2;
    sum <= sig1 + sig2 + sig3;
  end process;
end sig;

Sum = ?
```

2.6 Variables, Signals, Constants - Predefined VHDL Types

- Variables, signals, and constants can have any one of the _____ VHDL types or they can have a _____ type
- Predefined Types
 - bit – {'0', '1'}
 - boolean – {FALSE, TRUE}
 - integer – [$-2^{31} - 1$.. $2^{31} - 1$]
 - real – floating point number in range $-1.0E38$ to $+1.0E38$
 - character – legal VHDL characters including lower-uppercase letters, digits, special characters, ...
 - time – an integer with units fs, ps, ns, us, ms, sec, min, or hr

2.6 Variables, Signals, Constants - User Defined Type

- Common user-defined type is _____

```
type state_type is (S0, S1, S2, S3, S4, S5);
signal state : state_type := S1;
```
- If no initialization, the _____ is the leftmost element in the enumeration list (S0 in this example)
- VHDL is ***strongly typed*** => signals and variables of different types _____ be mixed in the same assignment statement, and ***no*** _____ is performed

2.7 Arrays - Syntax

- Example

```
type SHORT_WORD is array (15 downto 0) of bit;
signal DATA_WORD : SHORT_WORD;
variable ALT_WORD : SHORT_WORD := "0101010101010101";
constant ONE_WORD : SHORT_WORD := (others => '1');
```

- ALT_WORD(0) – rightmost bit
- ALT_WORD(5 downto 0) – low order 6 bits

- General form

```
type arrayTypeName is array index_range of element_type;
signal arrayName : arrayTypeName [:=InitialValues];
```

Page 59 of 78

2.7 Arrays – Syntax continued

- Multidimensional arrays

```
type matrix4x3 is array (1 to 4, 1 to 3) of integer;
variable matrixA: matrix4x3 :=
((1,2,3), (4,5,6), (7,8,9), (10,11,12));
```

- matrixA(3, 2) = ?

- Unconstrained array type

```
type intvec is array (natural range<>) of integer;
type matrix is array (natural range<>, natural range<>)
of integer;
```

- range must be specified when the _____

```
signal intvec5 : intvec(1 to 5) :=
(3,2,6,8,1);
```

Page 60 of 78

2.6 Variables, Signals, Constants - Predefined Unconstrained Array Types

```
type bit_vector is array (natural range <>) of bit;
type string is array (positive range <>) of character;
constant string1: string(1 to 29) := "This string is 29 characters."
```

```
constant A : bit_vector(0 to 5) := "10101";
-- ('1', '0', '1', '0', '1');
```

- Subtypes
- include a subset of the values specified by the type

```
subtype SHORT_WORD is : bit_vector(15 to 0);
```

- POSITIVE, NATURAL – predefined subtypes of type integer

Page 61 of 78

2.7 Arrays - Sequential Machine Model Using State Table

```
entity SM1_2 is
  port (X, CLK: in bit;
        Z: out bit);
end SM1_2;
```

```
architecture Table of SM1_2 is
  type StateTable is array (integer range <>, bit range <>) of integer;
  type OutTable is array (integer range <>, bit range <>) of bit;
  signal State, NextState: integer := 0;
  constant ST: StateTable (0 to 6, '0' to '1') :=
    ((1,2), (3,4), (4,4), (5,5), (5,6), (0,0), (0,0));
  constant OT: OutTable (0 to 6, '0' to '1') :=
    (('1','0'), ('1','0'), ('0','1'), ('0','1'), ('1','0'), ('0','1'), ('1','0'));
```

```
begin
  NextState <= ST(State,X); -- concurrent statements
  Z <= OT(State, X); -- read output from output table
  process(CLK)
  begin
    if CLK = '1' then -- rising edge of CLK
      State <= NextState;
    end if;
  end process;
end Table;
```

PS	NS		Z	
	X = 0	X = 1	X = 0	X = 1
S0	S1	S2	1	0
S1	S3	S4	1	0
S2	S4	S4	0	1
S3	S5	S5	0	1
S4	S5	S6	1	0
S5	S0	S0	0	1
S6	S0	-	1	-

Page 62 of 78

2.8 VHDL Operators – Precedence Relations

- Class 7 has the highest precedence (applied first), followed by class 6, then class 5, etc
1. Binary logical operators: **and or nand nor xor xnor**
 2. Relational: **= /= < <= > >=**
 3. Shift: **sll srl sla sra rol ror**
 4. Adding: **+ - &** (concatenation)
 5. Unary sign: **+ -**
 6. Multiplying: *** / mod rem**
 7. Miscellaneous: **not abs ****

2.8 VHDL Operators – Examples

In the following expression, A, B, C, and D are bit_vectors:

$(A \ \& \ \text{not } B \ \text{or } C \ \text{ror } 2 \ \text{and } D) = "110010"$

The operators would be applied in the order:

not, &, ror, or, and, =

If A = "110", B = "111", C = "011000", and D = "111011", the computation would proceed as follows:

not B = "000" (bit-by-bit complement)

A & **not** B = "110000" (concatenation)

C **ror** 2 = "000110" (rotate right 2 places)

(A & **not** B) **or** (C **ror** 2) = "110110" (bit-by-bit or)

(A & **not** B **or** C **ror** 2) **and** D = "110010" (bit-by-bit and)

[(A & **not** B **or** C **ror** 2) **and** D] = TRUE

(the parentheses force the equality test to be done last and the result is TRUE)

2.8 VHDL Operators – Shift Operator Examples

The shift operators can be applied to any `bit_vector` or `boolean_vector`. In the following examples, `A` is a `bit_vector` equal to "10010101":

A **sll** 2 is "01010100" (shift left logical, filled with '0')
 A **srl** 3 is "00010010" (shift right logical, filled with '0')
 A **sla** 3 is "10101111" (shift left arithmetic, filled with right bit)
 A **sra** 2 is "11100101" (shift right arithmetic, filled with left bit)
 A **rol** 3 is "10101100" (rotate left)
 A **ror** 5 is "10101100" (rotate right)

2.9 VHDL Functions - Introduction

- Functions execute a sequential algorithm and return a single value to calling program

```
function rotate_right (reg: bit_vector)
  return bit_vector is
begin
  return reg ror 1;
end rotate_right;
```

```
B <= rotate_right(A);
```

- General form

```
function function-name (formal-parameter-list)
  return return-type is
  [declarations]
begin
  sequential statements -- must include return return-value;
end function-name;
```

2.9 VHDL Functions – For Loops

General form of a for loop:

```
[loop-label:] for loop-index in range loop
    sequential statements
end loop [loop-label];
```

For Loop Example:

```
-- compare two 8-character strings and return TRUE if equal
function comp_string(string1, string2: string(1 to 8))
    return boolean is
    variable B: boolean;
begin
    loopex: for j in 1 to 8 loop
        B := string1(j) = string2(j);
        exit when B=FALSE;
    end loop loopex;
    return B;
end comp_string;
```

2.9 VHDL Functions - Add Function

```
-- This function adds 2 4-bit vectors and a carry.
-- It returns a 5-bit sum
```

```
function add4 (A,B: bit_vector(3 downto 0); carry: bit)
    return bit_vector is
```

```
    variable cout: bit;
    variable cin: bit := carry;
    variable Sum: bit_vector(4 downto 0):="00000";
begin
    loop1: for i in 0 to 3 loop
        cout := (A(i) and B(i)) or (A(i) and cin) or (B(i) and cin);
        Sum(i) := A(i) xor B(i) xor cin;
        cin := cout;
    end loop loop1;
    Sum(4):= cout;
    return Sum;
end add4;
```

Example function call:

```
Sum1 <= add4(A1, B1, cin);
```

2.10 VHDL Procedures - Introduction

- Procedures can return any number of values using output parameters
- General form

```

procedure procedure_name (formal-parameter-list) is
  [declarations]
begin
  Sequential-statements
end procedure_name;

procedure_name (actual-parameter-list);

```

2.10 VHDL Procedures – Procedure for Adding Bit_Vectors

-- This procedure adds two n-bit bit_vectors and a carry and
 -- returns an n-bit sum and a carry. Add1 and Add2 are assumed
 -- to be of the same length and dimensioned n-1 downto 0.

```

procedure Addvec
  (Add1,Add2: in bit_vector;
   Cin: in bit;
   signal Sum: out bit_vector;
   signal Cout: out bit;
   n:in positive) is
  variable C: bit;
begin
  C := Cin;
  for i in 0 to n-1 loop
    Sum(i) <= Add1(i) xor Add2(i) xor C;
    C := (Add1(i) and Add2(i)) or (Add1(i) and C) or (Add2(i) and C);
  end loop;
  Cout <= C;
end Addvec;

```

Example procedure call:

```
Addvec(A1, B1, Cin, Sum1, Cout, 4);
```

2.10 VHDL Procedures – Parameters for Subprogram Calls

Mode	Class	Actual Parameter	
		Procedure Call	Function Call
in ¹	constant ²	expression	expression
	signal	signal	signal
	variable	variable	n/a
out/inout	signal	signal	n/a
	variable ³	variable	n/a

¹ default mode for functions ² default for in mode ³ default for out/inout mode

2.11 Packages and Libraries

- Provide a convenient way of referencing frequently used functions and components
- Package header

```
package package-name is
  package declarations
end [package][package-name];
```

- Package body [optional]

```
package body package-name is
  package body declarations
end [package body][package name];
```

2.11 Packages and Libraries – Library BITLIB – bit_pack package

```

package bit_pack is
  function add4 (reg1,reg2: bit_vector(3 downto 0);carry: bit)
    return bit_vector;
  function falling_edge(signal clock:bit)
    return Boolean ;
  function rising_edge(signal clock:bit)
    return Boolean ;
  function vec2int(vec1: bit_vector)
    return integer;
  function int2vec(int1,NBits: integer)
    return bit_vector;
  procedure Addvec
    (Add1,Add2: in bit_vector;
     Cin: in bit;
     signal Sum: out bit_vector;
     signal Cout: out bit;
     n: in natural);

  component jkff
    generic(DELAY:time := 10 ns);
    port(SN, RN, J,K,CLK: in bit; Q, QN: inout bit);
  end component;

  component dff
    generic(DELAY:time := 10 ns);
    port (D, CLK: in bit; Q: out bit; QN: out bit := '1');
  end component;

  component and2
    generic(DELAY:time := 10 ns);
    port(A1, A2: in bit; Z: out bit);
  end component;

  component and3
    generic(DELAY:time := 10 ns);
    port(A1, A2, A3: in bit; Z: out bit);
  end component;

  component and4
    generic(DELAY:time := 10 ns);
    port(A1, A2, A3, A4: in bit; Z: out bit);
  end component;

  component or2
    generic(DELAY:time := 10 ns);
    port(A1, A2: in bit; Z: out bit);
  end component;

  component or3
    generic(DELAY:time := 10 ns);
    port(A1, A2, A3: in bit; Z: out bit);
  end component;

  ...
  (other component declarations go here)
  ...
end bit_pack;

```

Page 73 of 78

2.11 Packages and Libraries – Library BITLIB – bit_pack package

```

package body bit_pack is
  -- This function adds 2 4-bit numbers, returns a 5-bit sum
  function add4 (reg1,reg2: bit_vector(3 downto 0);carry: bit)
    return bit_vector is
    variable cout: bit:= '0';
    variable cin: bit:=carry;
    variable retval: bit_vector(4 downto 0):="00000";
  begin
    lp1: for i in 0 to 3 loop
      cout :=(reg1(i) and reg2(i)) or ( reg1(i) and cin) or
             (reg2(i) and cin );
      retval(i) := reg1(i) xor reg2(i) xor cin;
      cin := cout;
    end loop lp1;
    retval(4):=cout;
    return retval;
  end add4;

  -- Function for falling edge
  function falling_edge(signal clock:bit)
    return Boolean is
  begin
    return clock'event and clock = '0';
  end falling_edge;

  -- other functions and procedure declarations go here

end bit_pack;

```

Page 74 of 78

2.11 Packages and Libraries – Library BITLIB – bit_pack package

Components in Library BITLIB include:

```
-- 3 input AND gate
entity And3 is
  generic(DELAY:time);
  port (A1,A2, A3: in bit; Z: out bit);
end And3;
architecture concur of And3 is
begin
  Z <= A1 and A2 and A3 after DELAY;
end;

-- D Flip-flop
entity DFF is
  generic(DELAY:time);
  port (D, CLK: in bit;
        Q: out bit; QN: out bit := '1');
  -- initialize QN to '1' since bit signals are initialized to '0' by default
end DFF;
architecture SIMPLE of DFF is
begin
  process(CLK)
  begin
    if CLK = '1' then --rising edge of clock
      Q <= D after DELAY;
      QN <= not D after DELAY;
    end if;
  end process;
end SIMPLE;
```

Design of a Keypad Scanner

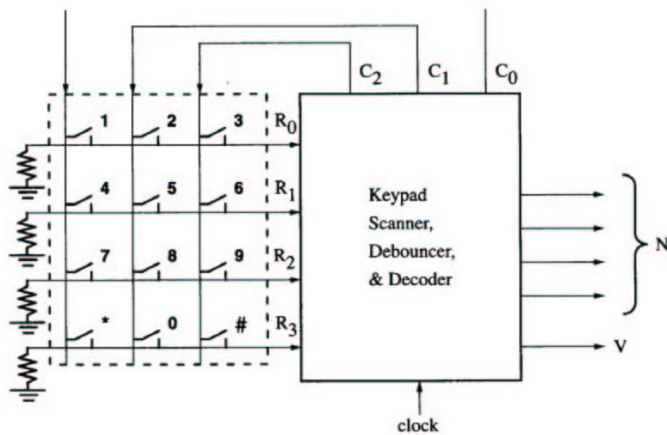

Design of a Keypad Scanner

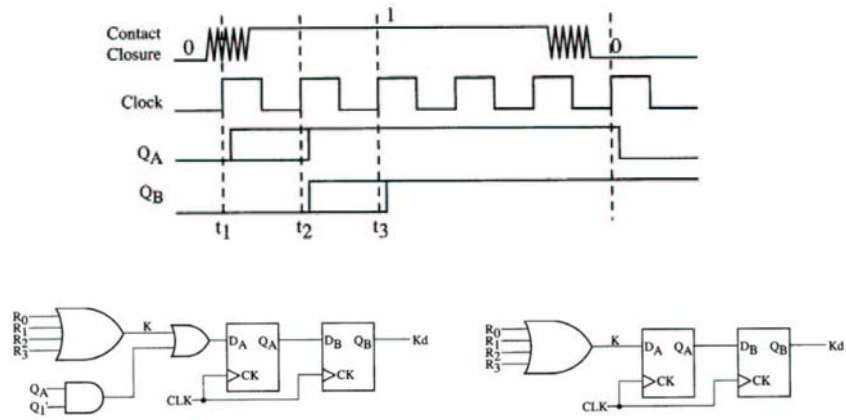

Design of a Keypad Scanner

